

A215/220 Series

DC-Operated, Gravity-Referenced
Servo Accelerometers

Sherborne Sensors
... the first choice in precision

Introduction

The Sherborne Sensors' range of Servo Accelerometers measure vector acceleration with high accuracy using a closed loop force balance torquer mechanism.

All A200 Series Accelerometers operate as a closed-loop torque balance servo system. Referring to the illustration below, the pendulous mass 'A' develops a torque proportional to the product of its mass unbalance and the applied acceleration.

The movement of mass 'A' is detected by position sensor 'B' whose output signal is connected to a servo amplifier. The resulting current is fed into the torquer motor 'C' which then develops a torque exactly equal to, but directly opposed to the initial

torque from the pendulous mass 'A'. Mass 'A' stops moving, assuming a position minutely differing from its zero 'g' position. Simultaneously, the current to the torquer motor is fed through a stable resistor to provide an output voltage proportional to the applied acceleration. The system is electronically damped by means of a phase advancing network within the integrated servo amplifier. By adjusting the parameters of the servo amplifier and related electronic networks, the operating characteristics of a servo accelerometer can be optimised to suit a particular application.

In addition to the instruments offered in this bulletin, Sherborne Sensors design custom accelerometers for specific applications, often manufactured and tested to conform to exacting military standards.

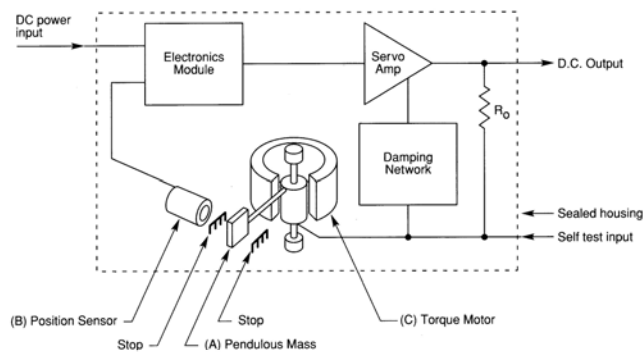

Features

- Available in ranges from $\pm 1g$ to $\pm 20g$
- High resolution down to 0.05 mg
- Closed loop force balance system
- Flight qualified versions available
- Self-Test facility
- DC Input – DC Output
- Manufactured to AS9100C and ISO 9001:2008 standards
- 1g bias option to compensate for earth's gravity (A220 only)

Applications

- Flight test monitoring
- Accident data collection
- Structural health monitoring
- Flight simulators
- Braking control in mass transit systems
- Road bed analysis
- Data acquisition systems
- Low frequency analysis



In North America: Email: nasales@sherbornesensors.com
Rest of World: Email: sales@sherbornesensors.com
Website: www.sherbornesensors.com



Sherborne Sensors, a Nova Metrix company



A215-220 - 2013 Iss 1

Specifications

Environmental Characteristics

Operating Temperature Range	°C (°F)	-55 to +95 (-67 to 203)
Survival Temperature Range	°C (°F)	- 65 to 105 (-85 to 221)
Constant Acceleration	g	100g in all 3 axes without damage
Shock		100g, 11ms ½ sine
Altitude	m (ft)	30,000 (98,400)
Environmental Sealing		IP65
EMC Directive		EN61326: 1998
EMC Emissions		EN55022: 1998
EMC Immunity		EN61000-4-2 inc A1: 1998 & A2: 2001 EN61000-4-3: 2002 EN61000-4-4: 2004 EN61000-4-6: 1996 inc A1: 2001 EN61000-4-8: 1994 inc A1: 2001

Specifications by Range @ +25°C (+77°F)

		± 1g	± 2g	± 5g	± 10g	± 20g
Excitation Voltage	Volts dc			± 15 (± 10%)		
Current Consumption	mA			<± 15		
Full Range Output (FRO) (see note 1)	Volts dc			± 5		
Output Standardisation	% FRO			± 1		
Output Impedance	Ω (nom)	5000	2500	5000	2500	5000
Output Noise (DC to 10kHz)	V rms			< 0.005		
Non-linearity (see note 2)	% FRO (max)	± 0.05	± 0.05	± 0.05	± 0.05	± 0.10
Hysteresis	% FRO (max)			0.02		
Resolution	% FRO (max)			0.0005		
Natural Frequency	Hz(min)	90	100	115	130	150
Sensitive Axis-to-Case Misalignment	deg			< ± 0.2		
Cross-axis Sensitivity (see note 3)	% FRO (max)	± 0.2	± 0.2	± 0.2	± 0.2	± 0.5
Zero Offset (see note 4)	% FRO			< ± 0.1		
Damping Ratio				0.6 ± 0.1		
Insulation Resistance	MΩ @ 50 Volts dc			≥ 20		
Thermal Zero Shift	%FRO/°C (%FRO/°F) (max)			≤ ± 0.002 (0.004)		
Thermal Sensitivity Shift	%Reading/°C (%Reading/°F)(max)			≤ ± 0.02 (0.04)		
Weight	Grams (ozs)			57 (2) A215; 115 (4.1) A220		

Notes

1. Full Range Output (FRO) is defined as the full acceleration excursion from positive to negative, i.e. ± 2g = 4g
2. Non-linearity is determined by the method of least squares
3. Cross-axis sensitivity is the output of unit when subjected to full range acceleration in cross-axis
4. Zero offset is specified under static conditions with no vibration inputs

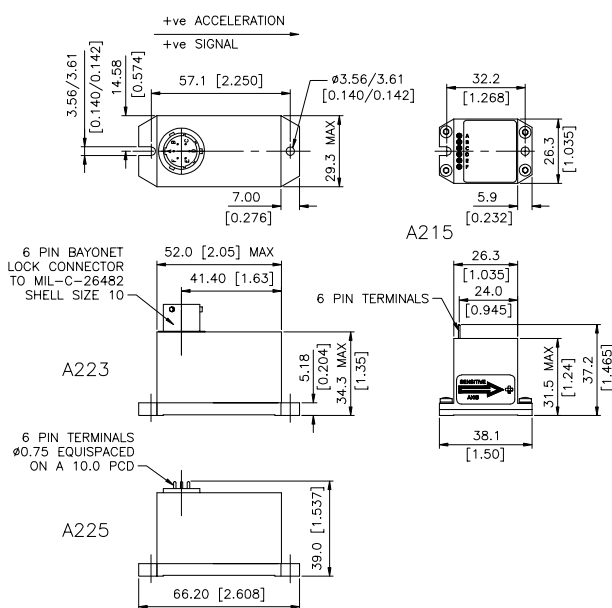

MODEL DESIGNATION & ORDERING CODE

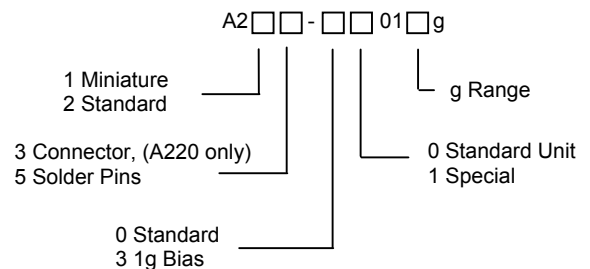

Specify Mating Connector 3CON-0009 if required (A220 only)

Electrical Connections

- Pin A +15V dc excitation
- Pin B 0V dc excitation/output
- Pin C -15V dc excitation
- Pin D ±5V dc output
- Pin E Not Connected
- Pin F Self Test



In North America: Email: nasales@sherbornesensors.com
 Rest of World: Email: sales@sherbornesensors.com
 Website: www.sherbornesensors.com



Sherborne Sensors, a Nova Metrix company