

# ED-18 ANALOG OUTPUT SERIES MAGNETIC ENCODER

Reliable and Consistent Rotational Feedback Sensor

## DESCRIPTION

The **ED-18 Series Magnetic Encoder** can be used as either a rotational feedback sensor or as a human machine interface (HMI) device. As a light duty feedback sensor it can provide rotation speed, direction or positioning information. The analog output provides absolute angular position information even when power is cycled on and off.

As an HMI device it can be used as a rotary input control for use on instrumentation panels. The ED-18 Series is designed with our modular and flexible construction methods. We can customize housings, shafts and terminations to meet your exact specifications with little or no tooling costs.

## FEATURES

- ◆ Magnetic Sensing Technology
- ◆ Encapsulated Electronics/Sealed unit
- ◆ Harsh Environment Compatibility
- ◆ Analog Voltage and Current Outputs
- ◆ Low Profile
- ◆ Consistent Rotational Torque
- ◆ Resistant to Contamination
- ◆ IP52 Sealing
- ◆ Metallic Threaded Bushing Mounting
- ◆ Wide Operational Temperature Range (-40°C to 85°C)
- ◆ Custom Housings, Shafts, Connectors Available in Most Cases with No Additional Tooling Required
- ◆ Sleeve Bearing
- ◆ Excellent Stability - No Optic Degradation



## APPLICATIONS

- ◆ Marine, Avionics, Motor Speed and Position Control
- ◆ Marine Steering & Throttle Position Control/Feedback
- ◆ Monitor Pump Speed & Direction
- ◆ Camera Position and Control
- ◆ X/Y Stage Positioning
- ◆ Radio Controls
- ◆ Medical Diagnostic Equipment
- ◆ Video and Sound Editing Equipment
- ◆ Valve Position
- ◆ Syringe Pump
- ◆ Potentiometer Replacement

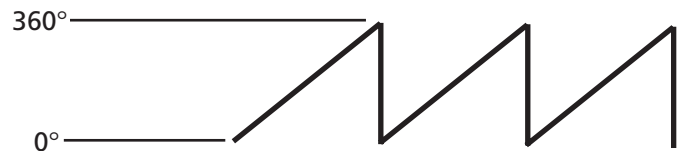

Sample Analog Output

Position Sensors Technical  
Support:

Tel: 757-766-4348

Fax: 757-766-4297

Email: [position@meas-spec.com](mailto:position@meas-spec.com)

**measurement**  
SPECIALTIES

# ED-18 SERIES MAGNETIC ENCODER

## performance specifications

Measurement Specialties reserves the right to update and change these specifications without notice.

Standard Outputs ranges over 360°	.5-4.5Vdc, 4-20mA, 0-5Vdc, 0-12Vdc, 0-20mA
Operating Temperature	-40°C to +85°C (Extended temperature range available, contact factory for details)
Maximum Speed	300 RPM
Bearing Life	3,000,000 cycles
Bearings	Sleeve
Run Out	.010" max @ .75 from mounting surface
Bushing Mounting Torque	10 in-lb max

### electrical

Current Draw	15 mA (+ output for current loop)
Operating Voltage (VDC)	5Vdc +/- .25 for .5-4.5Vdc & 0-5Vdc, 12.5-26 Vdc for current 15-26 Vdc for 0-12 Vdc

Note: All specifications are specified with Vdd @ Nominal input voltage, and Ambient Temperature 25 Degrees Celsius.

For current output max loop resistance 700Ω @ 24Vdc

### mechanical

Axial Load (lbs)	4.5 [20 N] Max.
Radial Load (lbs)	2.25 [10 N] Max.
Operating Speed (rpm)	300 = Sleeve 3000 = Ball
Shaft End Play (in)	.005 [.10] Max.
Shaft Radial Play (in)	.010 [.25] Max. @ .6 [15.2] from mounting surface
Shaft Push-in Force (lbs)	40 [9N]
Shaft Pull-out Force (lbs)	6 [1.3N]

### environmental

Vibration	MIL-STD-202F Method 204D Test Condition B
Shock	MIL-STD-202F Method 213B Test Condition C
Humidity	MIL-STD-202F Method 103B Test Condition A
Thermal Shock	MIL-STD-202F Method 107G Test Condition A
Operating Temperature	-40 to +85 °C
Storage Temperature	-55 to 125 °C

### ordering information

ED-18 - SB - RRRR - O - P

**Connection**  
P= pin header

**Analogue**  
V= Voltage  
I= Currents

**Output Ranges**  
0545 = .5-4.5Vdc  
0050 = 0-5.0Vdc  
0012 = 0-12.0Vdc  
0420 = 4-20mA  
0020 = 0-20mA

**Catalogue Units**  
ED-18-SB-0050-V-P  
ED-18-SB-0545-V-P  
ED-18-SB-0420-I-P

### Position Sensors Technical Support:

Tel: 757-766-4348

Fax: 757-766-4297

Email: position@meas-spec.com

# ED-18 SERIES MAGNETIC ENCODER

## dimensions

### SLEEVE BEARING

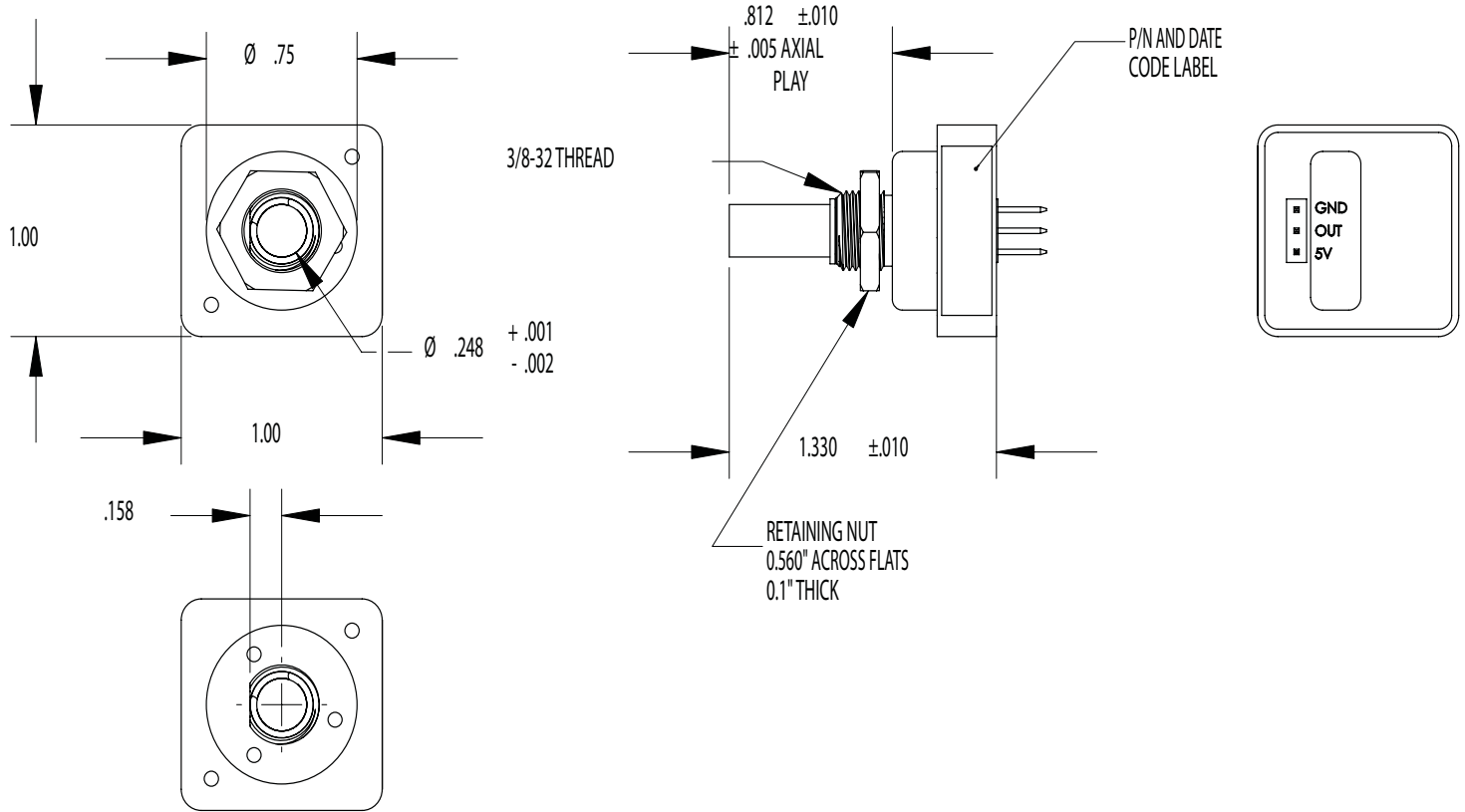

**Position Sensors Technical Support:**  
Tel: 757-766-4348  
Fax: 757-766-4297  
Email: position@meas-spec.com