

DC-SE Series

General Purpose LVDT

DESCRIPTION

The **DC-SE series** has been designed to meet today's requirements for operation from a single-ended power supply. The output is also single-ended over the full range displacement of the LVDT making the unit compatible with unipolar inputs on analog-to-digital converters and programmable logic controllers, etc.

The DC-SE design features internal regulation which provides immunity from line ripple and allows operation from an unregulated 8.5 to 28 VDC supply. The DC-SE current draw is 6 mA (typical), making remote or portable operation from batteries possible. The incorporation of a new high stability oscillator provides improved temperature stability, while the synchronous demodulator insures excellent noise rejection.

The electronics design uses surface mount technology to keep costs and size of the unit to a minimum. Built-in EMI/ESD protection and shielded cable allows operation in industrial environments. The DC-SE meets CE requirements.

FEATURES

- ◆ CE Certified
- ◆ Operates From Single-Ended, Unregulated 8.5–28 VDC Supply
- ◆ 0–5 VDC or 1–6 VDC Output Voltage, Depending on Customer Hook Up
- ◆ Low Power Consumption
- ◆ 200 Hz Frequency Response
- ◆ 1 Meter Shielded Cable
- ◆ Calibration Certificates Supplied with All Models

APPLICATIONS

- ◆ Positioning Sensing Feedback, Test Labs, Ram Guide and Platen Position Feedback

OPTIONS

- ◆ Metric Thread Core
- ◆ Guided Core
- ◆ Small Diameter/Low Mass Core
- ◆ Captive Core Option for Convenient Installation



specifications

Input Voltage	+8.5 to +28 VDC
Input Current	<10 mA (6 mA typical)
Line Regulation	<1mV/V (0.2mV/V typical)
Operating Temperature Range	-13°F to 185°F (-25°C to 85°C)
Storage Temperature Range	-65°F to +257°F (-55°C to 125°C)
Output Voltage	0–5 VDC (4 wire), 1–6 VDC (3 wire)
Ripple and Noise	Less than 10 mV rms
Linearity	0.25% full range
Stability	0.125% full scale
Temperature—Coefficient of Scale Factor	0.025%/°F (0.05%/°C) max
Shock Survival	250 g for 11 milliseconds
Vibration Tolerance	10 g up to 2 kHz
Housing Material	AISI 400 series stainless steel
Cable	4 conductor, 28 AWG stranded copper with braided shield and polyurethane jacket, 1 meter.
EMC	CE certified (The DC-SE series, when correctly installed, comply with the EMC Directive 89/336/EEC generic standards for residential commercial, light industrial and industrial environments.)
Output Impedance	Less than 1 ohm

ordering information

Specify the DC-SE Model followed by the desired option number(s) added together.

Ordering Example:

Model Number 250 DC-SE-200 is an DC-SE Series LVDT with a 0.250" range with the captive core option (200).

DC-SE Model

100 DC-SE
250 DC-SE
500 DC-SE
1000 DC-SE
2000 DC-SE
4000 DC-SE
6000 DC-SE

options

Number	Description
006	Metric Thread Core
010	Guided Core
020	Small Diameter, Low Mass Core ¹
200	Captive Core

¹Consult factory for mass, dimensions and thread size.



DC-SE Series

performance and electrical specifications¹

DC-SE Series Model Number	Nominal Linear Range		Scale Factor		Response
	inches	mm	V/inch	V/mm	-3 dB Hz
100 DC-SE	0 – 0.100	0 – 2.5	50	2.00	200
250 DC-SE	0 – 0.250	0 – 6.25	20	0.80	200
500 DC-SE	0 – 0.500	0 – 12.5	10	0.40	200
1000 DC-SE	0 – 1.000	0 – 25	5	0.20	200
2000 DC-SE	0 – 2.000	0 – 50	2.5	0.10	200
4000 DC-SE	0 – 4.000	0 – 100	1.25	0.05	200
6000 DC-SE	0 – 6.000	0 – 150	0.83	0.03	200

¹All calibration is performed at room ambient temperature.

DC-SE 3-wire hookup: 1 to 6V out

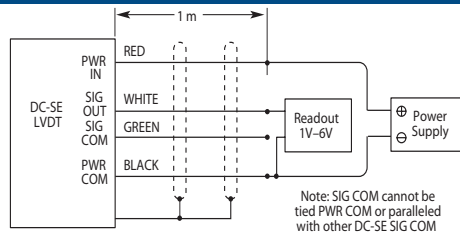

DC-SE 4-wire hookup: 0 to 5V out

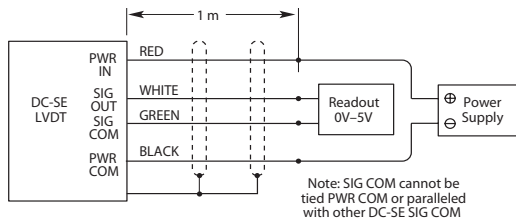

new captive core option!

The DC-SE features a captive core design that greatly simplifies installation. The design utilizes a core rod and bearing assembly that is captured and guided within the LVDT providing low friction travel throughout the stroke length. The assembly incorporates two Delrin bearings on the core rod traveling through the stainless steel boreliner. A bronze bearing on the front end utilizes a self-aligning feature to accommodate lateral LVDT movement during operation. The core rod and bearing assembly are field replaceable.



dimensions

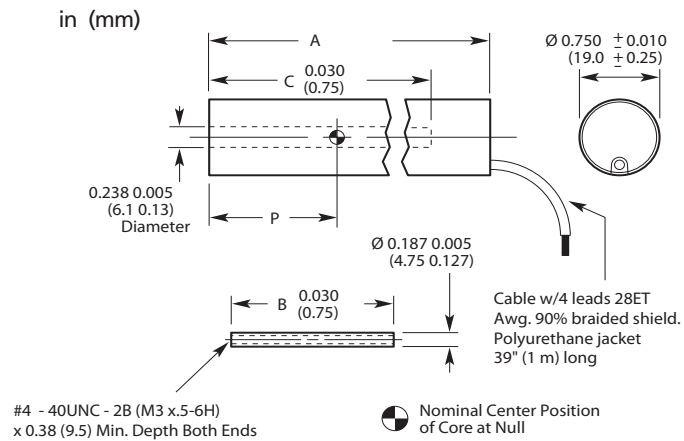

block diagram

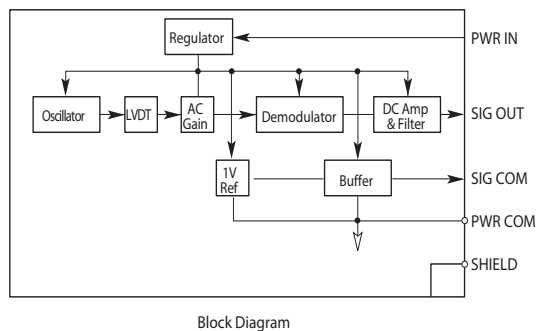

mechanical specifications

DC-SE Series Model Number	Body Weight		Core Weight		Dimensions							
	oz	gm	oz	gm	A (Body)		B (Core)		C	P		
					in	mm	in	mm	in	mm	in	mm
100 DC-SE	2.54	72	0.035	1	3.51	89.2	0.59	14.9	1.21	30.7	0.51	13.0
250 DC-SE	3.21	91	0.11	3	4.36	110.7	1.10	27.9	2.06	52.2	0.93	23.6
500 DC-SE	3.39	96	0.18	5	5.20	132.1	1.80	45.7	2.91	73.8	1.35	34.3
1000 DC-SE	4.38	124	0.28	8	6.89	175.0	3.00	76.2	4.59	116.7	2.20	55.9
2000 DC-SE	6.25	177	0.35	10	8.87	225.3	3.80	96.5	6.57	166.8	3.19	81.0
4000 DC-SE	8.33	236	0.53	15	12.25	311.2	5.30	134.6	9.95	252.8	4.88	124.0
6000 DC-SE	10.48	297	0.64	18	17.30	439.4	6.20	157.5	15.06	382.5	7.56	192.0