

Datalogger

DL/N



Technical Specifications

Pressure measuring range (mH2O)

	1 ... 5	> 5 ... 2	> 2 ... 25
Overpressure	3 bar	3 x FS (≥ 3 bar)	3 x FS
Burst pressure	> 200 bar	> 200 bar	> 200 bar
Accuracy, (1), (\pm % FS)	≤ 0.25	≤ 0.1	≤ 0.1
Thermal shift, (\pm % FS)			
Zero point 0...70°C	≤ 0.06	≤ 0.03	≤ 0.015
Zero point -25...85°C	≤ 0.08	≤ 0.04	≤ 0.02
Zero point -40...85°C	≤ 0.09	≤ 0.06	≤ 0.03
Span 0...70°C	≤ 0.015	≤ 0.015	≤ 0.015
Span -25...85°C	≤ 0.02	≤ 0.02	≤ 0.02
Span -40...85°C	≤ 0.05	≤ 0.05	≤ 0.05
Long term stability, (2)	< 0.5% FS / < 4 mbar	< 0.5% FS / < 4 mbar	< 0.1% FS / < 0.2% FS

(1) Zero based accuracy according to DIN16086, incl. hysteresis and repeatability at ambient temperature

(2) 1 year (typ. / max.)

Temperature range

Process temperature	-5...80 °C
Ambient temperature	-40...85°C
Storage temperature	-40...85°C

Functions

Data Transfer	Data transfer of last measurement period, data transfer of all data, data transfer for a defined time-period, the data will be represented in a txt.file or in a graph
Resolution	< 0.01% FS
Real time clock	Quartz-precision clock with date, Start-time of datalogging configurable
Data memory	130'000 measurement values / non volatile, data kept in memory even without battery
Interface	RS232C / 9600 Baud
Identification	Each datalogger has a unique serial number, as well as a user-definable description
Power supply	1 x Lithium battery 3.6 V / size AA (on site battery change)
Protection class	IP 65 (cap closed)
Configuration	Sampling rate, number of replicates, time and date, description, starting time of first sample, tare, storage threshold value, density of the measuring media
Configuration	Sampling rate, number of replicates, time and date, description, starting time of first sample, tare, storage threshold value, density of the measuring media
Data format	Data are stored in an ASCII format file and can be processed with Excel™, Lotus™ or similar

System Requirements

PC	Processor: Min. 200 MHz Memory: Min. 50 MB RAM: Min. 64 MB
Operating system	Windows 2000 (Service Pack 4) / XP (Service Pack 3/32-Bit) / Vista (32-Bit) / 7 (32-Bit)

Qualifications

	Description	Level	Typical interferences
EN 61000-4-2	Electrostatic discharge	4 kV contact 8 kV air	
EN 61000-4-3	Irradiated RF	10 V/m (0.08...2.7 GHz, 3s)	Radio sets, wireless phones

Physical specifications

Materials	
Transducer	Stainless steel (316L / 1.4435), (1)
Housing level transmitter	Stainless steel (316L / 1.4404)
Seals Standard	Viton (Standard), EPDM, Kalrez
Housing datalogger	Aluminium AIMgCi1
Cap	POM

(1) Hastelloy (C-276) on request

Equipment

Overview

10.00.0091	Accessories overview

Software

101087	PC Software V2.26

Additional documents

Manual

	Article number	Description
10.00.0205	DEB016	Operating instructions

Operating and safety instructions

	Article number
10.88.0368	DMM031

Ordering information

		X. XXXX.	XXXX.	XX.	XXX
Type	DL/N	DL/N			
Pressure type	Gauge	1			
	Absolute (vacuum)	2			
Pressure measuring range	Any pressure measuring ranges between 0...1 mH2O and 0...250 mH2O available, (1)	XX			
Process connection	Open, (Fig. 7)	56			
	Closed, (Fig. 6)	55			
Electrical connection	RSF 5, 5-pin		08		
	PE cable, IP 68, (2), (3), (4)		13		
	PUR cable, IP 68, (2), (3), (5)		15		
	PTFE cable, IP 68, (2), (3)		21		
Output signal	RS232C		61		
Accuracy	≤ ± 0.25% FS (≤ 500 mbar)			1	
	≤ ± 0.1% FS (> 500 mbar)			2	
Temperature range	-5...50 °C compensated (allowed process temperature: -5...50 °C)			4	
	-5...80 °C compensated (allowed process temperature: -5...80 °C)			5	
Option 1	Special oil filling: ASEOL Food (for food applications)				G
	Special oil filling: Halocarbon (for oxygen applications)				H
Option 2	Electronics packed in gel: Gauge pressure				C
	Electronics packed in gel: Absolute pressure				D
Option 3	Seals: Viton (standard)				U
	Seals: EPDM				S
	Seals: Kalrez				T

(1) mH2O, mWS, mWC etc. available

(2) Connecting cable between TM/N and datalogger

(3) Please specify the required cable length and medium

(4) Suitable for drinking water (food approved)

(5) For medium temperature > 50°C a PE or teflon cable must be used

Technical drawings

Pressure Connections

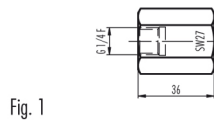

Fig. 1

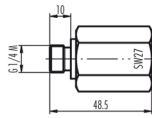

Fig. 2

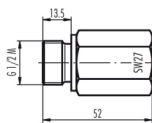

Fig. 3

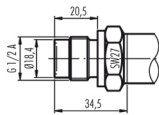

Fig. 4

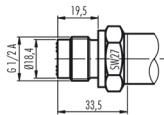

Fig. 5

Dimensions

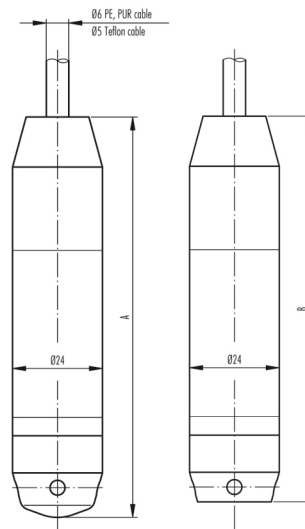
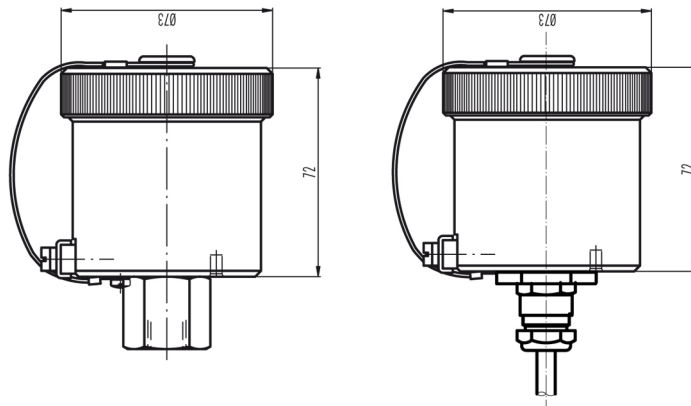

Fig. 6

Fig. 7

	A [mm]	B [mm]	C [mm]	D [mm]	Weight [g]
without ballast weight	85	81	on request	on request	approx. 200
with ballast weight	172	168	on request	on request	approx. 450

Specifications may change without notice.

STS Great Britain:

STS Great Britain Ltd.
Box 3942 | Warwick | CV34 9AE, United Kingdom
contact@stssensors.com | www.stssensors.co.uk

STS Headquarters, Switzerland:

STS Sensor Technik Sirmach AG
Rüthofstrasse 8, 8370 Sirmach, Switzerland
sales@stssensors.com | www.stssensors.com

STS France:

STS France
844 Route de la Caille, 74350 Allonzier la Caille, France
info-fr@stssensors.com | www.stssensors.fr

STS Germany:

STS Sensoren Transmitter Systeme GmbH
Poststrasse 7, 71063 Sindelfingen, Germany
info-de@stssensors.com | www.stssensors.de

STS Italy:

STS Italia s.r.l.
Via Gesù 5, 20090 Opera (Milano), Italy
info-italia@stssensors.com | www.stssensors.it