

Model 4203 Accelerometer

Triaxial Accelerometer
Critically Gas Damped
Silicon MEMS Technology
Temperature Compensation
EMI/RFI Protection
Custom 8-Pole LP Filters



The Model 4203 Triaxial Accelerometer is designed with performance and reliability in mind. The rugged Piezoresistive MEMS sensing element comes straight from our world renowned crash test accelerometers. The internal ASIC amplifier performs sensitivity and zero compensation 20 times per second over its operating temperature. The low-pass corner frequency can be custom ordered. Its 8-pole filter ensures no high frequency noise will leak into the passband. A heavy-duty shielded cable and an EMI/RFI module protects the accelerometer from the harsh operating environment, including ESD damage.

FEATURES

- 8-16 Vdc Excitation
- Ranges up to ± 30 g's full scale
- Measures static & dynamic acceleration
- Over shock protection to $\pm 5,000$ g's
- Operating temperature from -40 to 125°
- Built-in 8-pole low-pass filter
- EMI/RFI protection
- Linearity $\pm 1\%$ FS
- Transverse sensitivity $< 1\%$ available

APPLICATIONS

- Formula One
- NASCA
- Champ Car
- Indy Racing League

dimensions

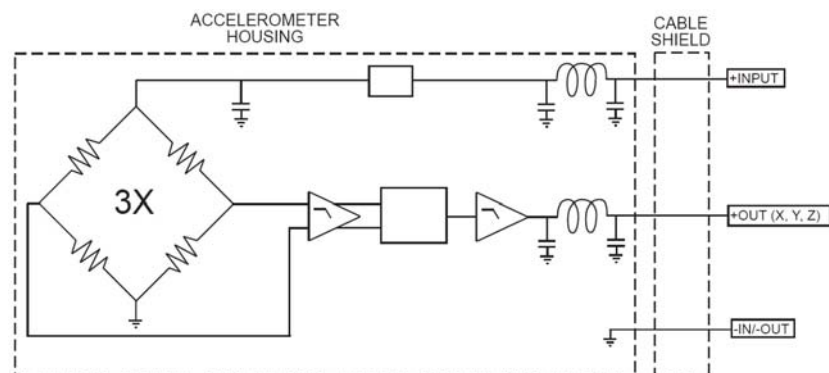
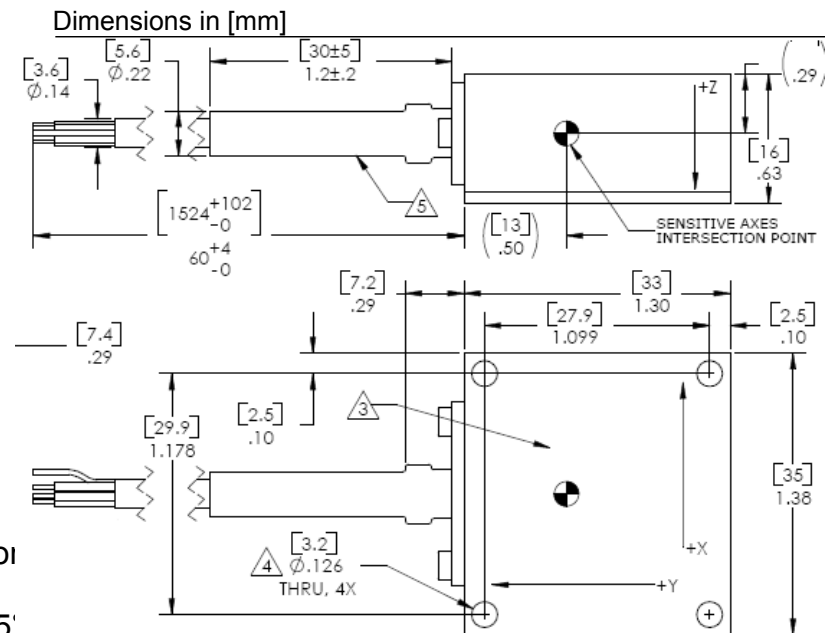

Model 4203 Accelerometer



performance specifications

All values are typical at $\pm 24^{\circ}\text{C}$, and 10 Vdc excitation unless otherwise stated. Measurement Specialties reserves the right to update and change these specifications without notice. Standard product parameters are described in PSC-1004 for Plug & Play DC Accelerometers

Parameters	-06	-08	-10	-20	-30	Notes
DYNAMIC						Dash Number
Range(g)	± 6	± 7.5	± 10	± 20	± 30	
Sensitivity (mV/g)	333	267	200	100	67	$\pm 5\%$
Standard Frequency Response (Hz)	0 to 60	0 to 60	0 to 60	0 to 60	0 to 60	Or custom order
Customizable LP Corner Freq. (Hz)	5 to 100	5 to 100	5 to 100	5 to 100	5 to 100	-3dB, -160dB/decade
Shock Limit (g)	5000	5000	5000	5000	5000	
Non-Linearity (% FSO)	± 1	± 1	± 1	± 1	± 1	
Transverse Sensitivity (%)	$<3/<1.5$	$<3/<1.5$	$<3/<1.5$	$<3/<1.5$	$<3/<1.5$	Standard/Optional
Zero Acceleration Output (mV)	± 100	± 100	± 100	± 100	± 100	From 2.5Vdc bias
Thermal Zero Shift (%FSO/50°C)	$\pm 2.5/\pm 1.5$	$\pm 2.5/\pm 1.5$	$\pm 2.5/\pm 1.5$	$\pm 2.5/\pm 1.5$	$\pm 2.5/\pm 1.5$	Standard/Optional
Thermal Sensitivity Shift (%/50°C)	$\pm 2.5/\pm 1.5$	$\pm 2.5/\pm 1.5$	$\pm 2.5/\pm 1.5$	$\pm 2.5/\pm 1.5$	$\pm 2.5/\pm 1.5$	Standard/Optional
ELECTRICAL						
Excitation (Vdc)	8 to 16	8 to 16	8 to 16	8 to 16	8 to 16	
Current (mA)	<5	<5	<5	<5	<5	
Output Impedance (Ω)	<100	<100	<100	<100	<100	
Insulation Resistance ($M\Omega$)	>100	>100	>100	>100	>100	@50Vdc
PHYSICAL						
Case Material	Al Alloy	Al Alloy	Al Alloy	Al Alloy	Al Alloy	Anodized
Cable (Teflon Jacket, 5 wire+shield)	24 AWG	24 AWG	24 AWG	24 AWG	24 AWG	Teflon insulated
Weight (grams)	<60	<60	<60	<60	<60	Without cable
Mounting			M3 Screws			4X
ENVIRONMENTAL						
Operating Temperature ($^{\circ}\text{C}$)			-40 to +85			
Sealing						Potted Construction

PART NUMBERING

4203-XX-YY-ZZ-WW where XX, YY, ZZ represent the g ranges for each of the 3 axes, WW is optional frequency cutoff.

Wiring color code: +Input = Red; -Input/+Output = Black; +Output X = Green; +Output Y = Blue; +Output Z = White

The information in this sheet has been carefully reviewed and is believed to be accurate; however, no responsibility is assumed for inaccuracies. Furthermore, this information does not convey to the purchaser of such devices any license under the patent rights to the manufacturer. Measurement Specialties, Inc. reserves the right to make changes without further notice to any product herein. Measurement Specialties, Inc. makes no warranty, representation or guarantee regarding the suitability of its product for any particular purpose, nor does Measurement Specialties, Inc. assume any liability arising out of the application or use of any product or circuit and specifically disclaims any and all liability, including without limitation consequential or incidental damages. Typical parameters can and do vary in different applications. All operating parameters must be validated for each customer application by customer's technical experts. Measurement Specialties, Inc. does not convey any license under its patent rights nor the rights of others.

ordering info

North America

Measurement Specialties, Inc.
1000 Lucas Way
Hampton, VA 23666
Tel: 1-800-555-1551
Fax: 1-757-766-4297
Sales: sales@meas-spec.com

Europe

Measurement Specialties, Inc.
26 Rue des Dame
F78340 Les Clayes-sous-Bois, France
Tel: +33 (0) 1 30 79 33 00

Asia

Measurement Specialties, Inc
No. 26 Langshan Road
Shenzhen High-Tech Park (North)
Nanshan District, Shenzhen 518107
Tel: +86 755 33305088
Fax: +86 755 33305099
Sales: sales.china@meas-spec.com