

82 Constant Voltage



- 316L SS Pressure Sensor
- 19mm Diameter Package
- 0 - 100mV Output
- Absolute and Gage
- Temperature Compensated

DESCRIPTION

The 82 constant voltage is a 19 mm small profile, media compatible, piezoresistive silicon pressure sensor packaged in a 316L stainless steel housing. The 82 constant voltage is designed for o-ring mounting and OEM applications where compatibility with corrosive media is required.

The sensing package utilizes silicone oil to transfer pressure from the 316L stainless steel diaphragm to the sensing element. A ceramic substrate is attached to the package that contains laser-trimmed resistors for temperature compensation and offset correction.

Please refer to the 82 uncompensated and compensated datasheets for more information on different features of the 82.

FEATURES

- O-Ring Mount
- -40°C to +125°C Operating Temperature Range
- ±0.2% Pressure Non Linearity
- 1.0% Interchangeable Span (provided by gain set resistor)
- Solid State Reliability

APPLICATIONS

- Medical Instruments
- Process Control
- Fresh & Waste Water Measurements
- Partial Vacuum Gas Measurement
- Pressure Transmitters
- Tank Level Systems (RV & Industrial)

STANDARD RANGES

Range	psia	psig
0 to 1		•
0 to 5	•	•
0 to 15	•	•
0 to 30	•	•
0 to 50	•	•
0 to 100	•	•
0 to 300	•	•
0 to 500	•	•

82 Constant Voltage

PERFORMANCE SPECIFICATIONS

Supply Voltage: 10Vdc

Ambient Temperature: 25°C (unless otherwise specified)

PARAMETERS	001PSI			005PSI			≥015PSI			UNITS	NOTES
	MIN	TYP	MAX	MIN	TYP	MAX	MIN	TYP	MAX		
Span	77	80	83	98	100	102	99	100	101	mV	1
Zero Pressure Output	-2	0	2	-2	0	2	-1	0	1	mV	
Pressure Non Linearity	-0.3		0.3	-0.2		+0.2	-0.1		0.1	%Span	2
Pressure Hysteresis	-0.10	±0.02	0.10	-0.10	±0.02	0.10	-0.05	±0.02	0.05	%Span	
Repeatability		±0.02			±0.02			±0.02		%Span	
Input Resistance	5.5	9.0	12.5	5.5	9.0	12.5	5.5	9.0	12.5	KΩ	
Output Resistance	4.0		7.0	4.0		7.0	4.0		6.0	KΩ	
Thermal Hysteresis – Span	-0.25	±0.05	0.25	-0.25	±0.05	0.25	-0.25	±0.05	+0.25	%Span	3
Thermal Hysteresis – Offset	-0.25	±0.05	0.25	-0.25	±0.05	0.25	-0.25	±0.05	+0.25	%Span	3
Temperature Error – Span	-1.0		1.0	-1.0		1.0	-1.0		1.0	%Span	3
Temperature Error – Offset	-1.0		1.0	-1.0		1.0	-1.0		1.0	%Span	3
Long Term Stability – Span		±0.10			±0.10			±0.10		%Span	4
Long Term Stability – Offset		±0.25			±0.25			±0.10		%Span	4
Supply Voltage		10	14		10	14		10	14	V	
Output Load Resistance	5			5			5			MΩ	
Insulation Resistance (50Vdc)	50			50			50			MΩ	5
Output Noise (10Hz to 1KHz)		1			1			1		uV p-p	
Response Time (10% to 90%)		0.1			0.1			0.1		ms	
Pressure Overload			10x			3x			3x	Rated	6
Pressure Burst			12x			4x			4x	Rated	
Operating Temperature	-20		+70	-20		+70	-40		+125	°C	
Compensated Temperature	0		+50	0		+70	-20		+85	°C	
Storage Temperature	-40		+125	-40		+125	-40		+125	°C	7
Media – Pressure Port	Liquids and Gases compatible with 316L Stainless Steel and Buna-N										8
Media – Reference Port	Compatible with Silicon, Pyrex, Gold, Fluorosilicone RTV and 316L Stainless Steel										

Notes

1. Ratiometric to supply voltage.
2. Best fit straight line.
3. Maximum temperature error within the compensated temperature range with respect to 25°C.
4. Long term stability over a one year period with constant current and temperature.
5. Minimum resistance between case and pins.
6. 10 psi maximum for 1 psi devices.
7. Maximum temperature range for product with standard cable and connector is -20°C to +105°C.
8. Gage units not recommended for high vacuum applications. For high vacuum applications consult factory.

82 Constant Voltage

DIMENSIONS

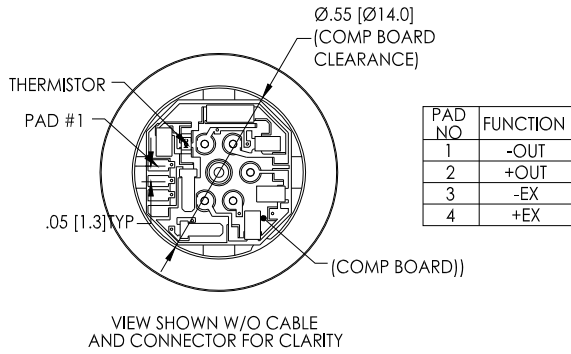
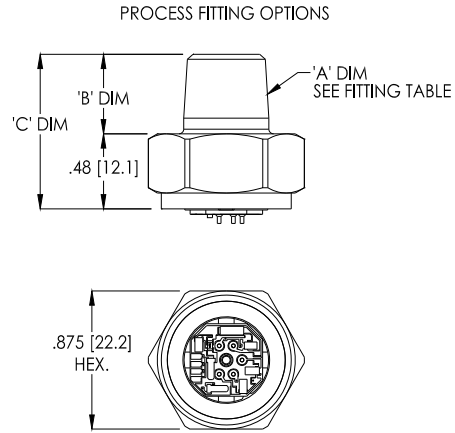
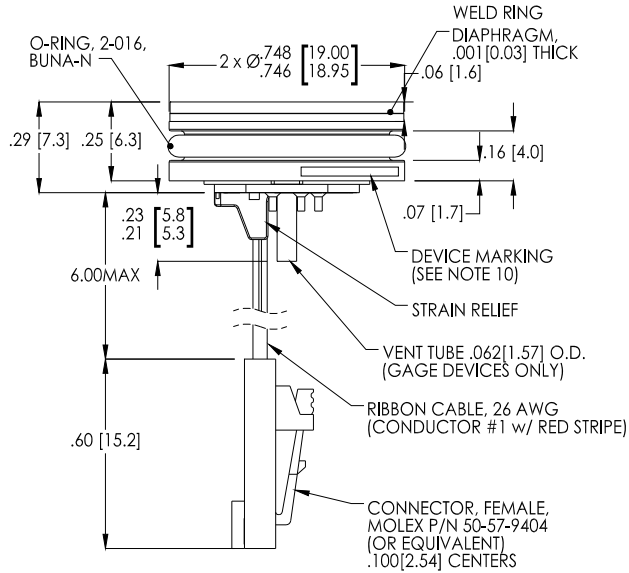

FITTING TABLE				
FITTING TYPE	MEMS P/N	'A' DIM	'B' DIM	'C' DIM
1	IC-7152	1/4-18 NPT	.50 [12.7]	.98 [24.9]
2	IC-D00510	1/8-27 NPT	.47 [11.9]	.95 [24.1]
3	IC-D00511	7/16-20 UNF	.33 [8.4]	.80 [20.3]
9	IC-D00512	1/4-19 BSP	.45 [11.4]	.93 [23.3]

NOTE: FITTING TYPE '1' ASSEMBLT SHOWN
ALL DIMS ARE FOR REFERENCE.

DIMENSIONS ARE IN INCHES [mm]

CONNECTIONS

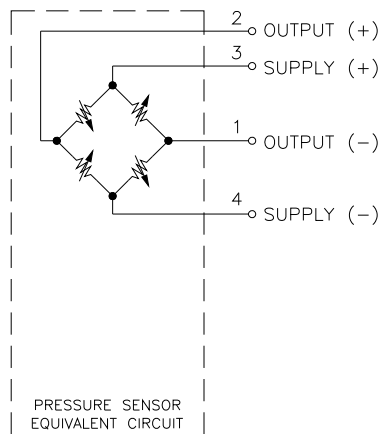

82 Constant Voltage

APPLICATION SCHEMATIC

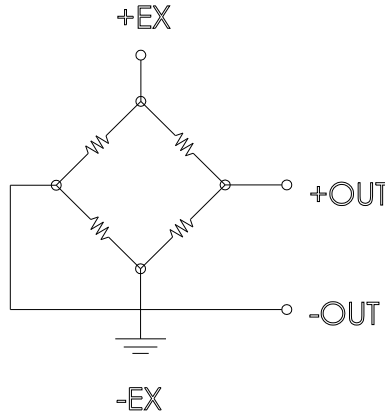

EQUIVALENT SCHEMATIC

ORDERING INFORMATION

82CV - 050 G - 1 C T

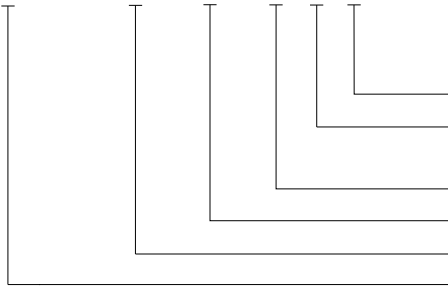

Vent (T = Tube, Blank = No Tube)
Electrical (R = Ribbon Cable,
C = Cable with connector)
Fitting Type (Blank = No Fitting/Weldable, See Fitting Table)
Type (A = Absolute, G = Gage)
Pressure Range
Model

NORTH AMERICA

Measurement Specialties
45738 Northport Loop West
Fremont, CA 94538
Tel: 1-800-767-1888
Fax: 1-510-498-1578
Sales: pfg.cs.amer@meas-spec.com

EUROPE

Measurement Specialties
(Europe), Ltd.
26 Rue des Dames
78340 Les Clayes-sous-Bois, France
Tel: +33 (0) 130 79 33 00
Fax: +33 (0) 134 81 03 59
Sales: pfg.cs.emea@meas-spec.com

ASIA

Measurement Specialties
(China), Ltd.
No. 26 Langshan Road
Shenzhen High-Tech Park (North)
Nanshan District, Shenzhen 518057
China
Tel: +86 755 3330 5088
Fax: +86 755 3330 5099
Sales: pfg.cs.asia@meas-spec.com

The information in this sheet has been carefully reviewed and is believed to be accurate; however, no responsibility is assumed for inaccuracies. Furthermore, this information does not convey to the purchaser of such devices any license under the patent rights to the manufacturer. Measurement Specialties, Inc. reserves the right to make changes without further notice to any product herein. Measurement Specialties, Inc. makes no warranty, representation or guarantee regarding the suitability of its product for any particular purpose, nor does Measurement Specialties, Inc. assume any liability arising out of the application or use of any product or circuit and specifically disclaims any and all liability, including without limitation consequential or incidental damages. Typical parameters can and do vary in different applications. All operating parameters must be validated for each customer application by customer's technical experts. Measurement Specialties, Inc. does not convey any license under its patent rights nor the rights of others.