

P-Series Inclinometer



- Single or Dual axis inclinometer
- Measurement range $\pm 5^\circ$, $\pm 15^\circ$ and $\pm 45^\circ$
- High accuracy
- Digital and analogue output signal

DESCRIPTION

The **P-Series** of conductive inclinometers offers modern technology in an environmentally protected and robust aluminium housing in IP class 65. The inclinometer achieves high accuracy over a wide temperature range. All P-type inclinometers are microprocessor controlled transducers capable of producing a linearized RS-232 digital and analog voltage $\pm 1.5V$ or current output $4 \dots 20$ mA signal. The inclinometers are an ideal choice for a variety of industrial, automotive and aerospace applications.

FEATURES

- Measurement range up to $\pm 45^\circ$
- High resolution
- Robust metal housing
- High accuracy
- Rugged M9 female connector
- Programmable zero point, baud rate
- Easy mounting

APPLICATIONS

- Building control
- Road construction machines
- Weighing systems
- Mobile and stationary cranes
- Hydraulic leveling
- Platform leveling
- Drilling machines

P-Series Inclinator

PERFORMANCE SPECIFICATIONS

	Conditions	Min	Type	Max	Unit
Measurement range		-5/ -15/ -45		+5/ +15/ +45	°
Resolution		0.001		0.005	°
Accuracy, digital output	Ta = +25°C		0.02/ 0.03/ 0.4		°
Accuracy, analogue output	Ta = +25°C		0.05/ 0.06/ 0.6		°
Accuracy, digital output	Ta = -25°C ...+85°C		0.2/ 0.4/ 0.7		°
Accuracy, analogue output	Ta = -25°C ...+85°C		0.25/ 0.5/ 0.8		°
Noise RMS			0.002		°
Power supply		+6.5		+24	VDC
Current consumption	Depending on kind of sensor		30	40	mA
Operation temperature range		-25		+85	°C
Storage temperature range		-40		+85	°C
Transmission rate	RS 232 interface		1		Hz
Baud rate, programmable	RS 232 interface	2.4		9.6	kB
Current output (1)	NS-xx/PI	20		4	mA
Voltage output (2)	NS-xx/P	-1.5		+1.5	V
Weight	Depending on kind of sensor	210		340	g
Dimensions	Single axis unit, W x D x H		90 x 40 x 45.5		mm
Dimensions	Dual axis unit, W x D x H		90 x 60 x 45.5		mm

(1) Standard impedance $Z_a < 160 \text{ Ohm}$, special impedance $Z_a < 260 \text{ Ohm}$ on request

(2) Ratiometric to GNDx

P-Series Inclinometer

DIMENSIONS [MM]

Single axis unit:

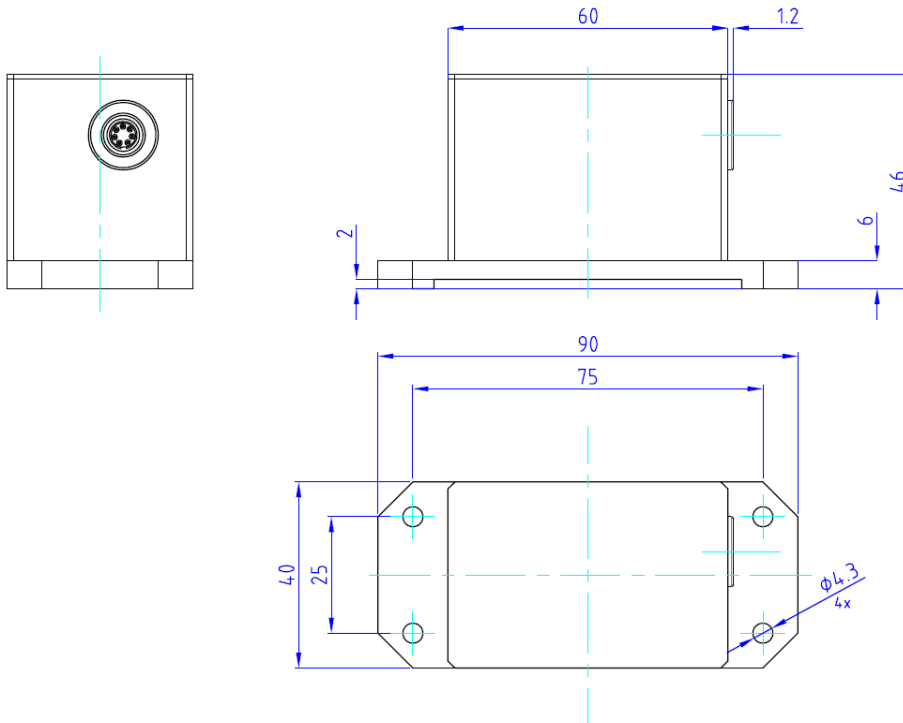

Dual axis unit:

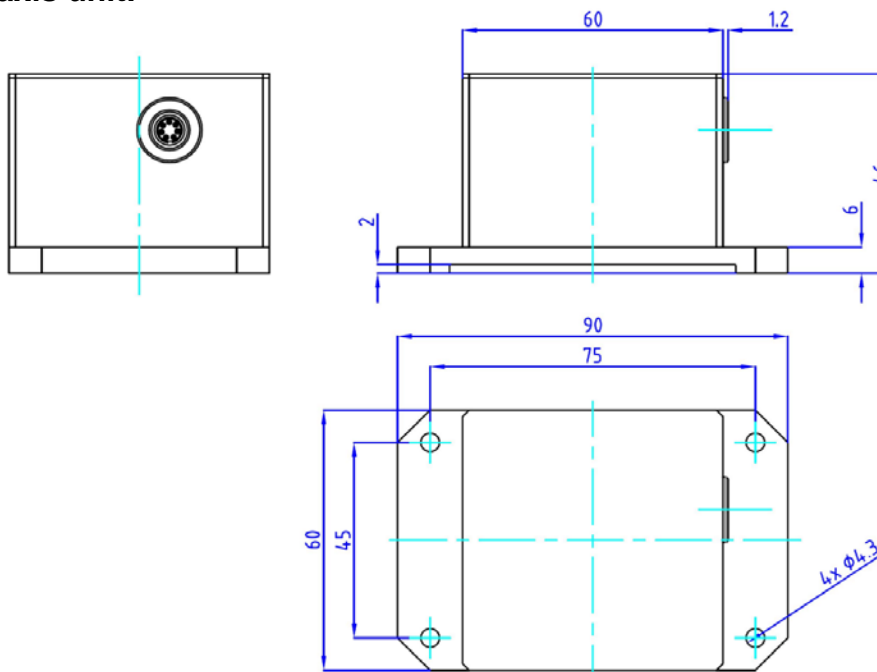

P-Series Inclinator

PINNING – SINGLE AXIS UNIT WITH RS 232 INTERFACE AND CURRENT OUTPUT

Pin	Name	Description	Type	Color schema ⁽¹⁾
1	Vcc	power supply +6.5...+24VDC	supply	white
2	GND	power supply ground, RS 232 ground	supply	brown
3	Earth	earth	supply	green
4	GNDx	signal ground for current output	supply	yellow
5	Out x	x-axis current output 4...20mA	output	grey
6	RxD	input digital signal RS232	input	pink
7	TxD	output digital signal RS 232	output	blue

(1) by using a Measurement Specialties cable

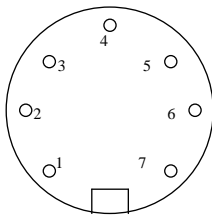

Front view of housing
connector inclinometer

For more details please use the product specification / application note / instruction manual.

PINNING – SINGLE AXIS UNIT WITH RS 232 INTERFACE AND VOLTAGE OUTPUT

Pin	Name	Description	Type	Color schema ⁽¹⁾
1	Vcc	power supply +6.5...+24VDC	supply	white
2	GND	power supply ground, RS 232 ground	supply	brown
3	Earth	earth	supply	green
4	GNDx	signal ground for voltage output	supply	yellow
5	Out x	x-axis voltage output +/-1.5V	output	grey
6	RxD	input digital signal RS232	input	pink
7	TxD	output digital signal RS 232	output	blue

(1) by using a Measurement Specialties cable

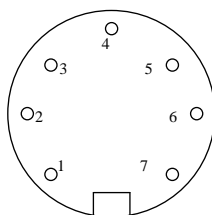

Front view of housing
connector inclinometer

For more details please use the product specification / application note / instruction manual.

P-Series Inclinometer

PINNING – DUAL AXIS UNIT WITH RS 232 INTERFACE

Pin	Name	Description	Type	Color schema ⁽¹⁾
1	Vcc	power supply +6.5...+24VDC	supply	white
2	GND	power supply ground, RS 232 ground	supply	brown
3	Earth	earth	supply	green
4	n.c.	n.c.	-	yellow
5	n.c.	n.c.	-	grey
6	RxD	input digital signal RS232	input	pink
7	TxD	output digital signal RS 232	output	blue

(1) by using a Measurement Specialties cable

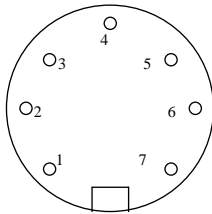

Front view of housing
connector inclinometer

For more details please use the product specification / application note / instruction manual.

DESCRIPTION DIGITAL RS 232 INTERFACE

	Single axis unit	Dual axis unit
Baud rate:	2400(*)/9600 baud	2400(*)/9600 baud
Format:	ASCII, 8 data bits, 1 stop bit, no parity	ASCII, 8 data bits, 1 stop bit, no parity
String length:	9 byte	22 byte
Layout:	< D ₀ ,D ₁ ,D ₂ ,D ₃ ,D ₄ ,D ₅ ,D ₆ ,D ₇ ,D ₈ >	< D ₀ ... D ₂₁ >
	D ₀ = sign	D ₀ ... D ₈ = "X"; "=" + (-); "xx.xxx"
	D ₁ ...D ₆ = angle (XX.XXX)	D ₂ = sign (+ or -)
	D ₃ = point	D ₅ = point
	D ₇ =<CR>	D ₉ =<CR>
	D ₈ =<LF>	D ₁₀ =<LF>
		D ₁₁ ... D ₂₁ = "Y"; "=" + (-); "yy.yyy"
		D ₁₃ = sign (+ or -)
		D ₁₆ = point
		D ₂₀ =<CR>
		D ₂₁ =<LF>

(*) default value

P-Series Inclinator

ORDERING INFORMATION

PART NUMBERING	UNIT	SHORT DESCRIPTION
Single axis unit		
G-NSP-001	NS-5/P	single axis, +/-5° angle, Vcc +6.5...24VDC, output +/-1.5V,RS232
G-NSPI-001	NS-5/PI	single axis, +/-5° angle, Vcc +6.5...24VDC, output 4...20 mA,RS232
G-NSP-002	NS-15/P	single axis, +/-15° angle, Vcc +6.5...24VDC, output +/-1.5V,RS232
G-NSPI-002	NS-15/PI	single axis, +/-15° angle, Vcc +6.5...24VDC, output 4...20 mA,RS232
G-NSP-005	NS-45/P	single axis, +/-45° angle, Vcc +6.5...24VDC, output +/-1.5V,RS232
G-NSPI-006	NS-45/PI	single axis, +/-45° angle, Vcc +6.5...24VDC, output 4...20 mA,RS232
Dual axis unit		
G-NSP2-001	NS-5/P2	dual axis, +/-5° angle, Vcc +6.5...24VDC, output RS232
G-NSP2-003	NS-15/P2	dual axis, +/-15° angle, Vcc +6.5...24VDC, output RS232
G-NSP2-006	NS-45/P2	dual axis, +/-45° angle, Vcc +6.5...24VDC, output RS232
Accessories		
G-NSMIS-001	connection	connector, straight, Submin. 712-series
G-NSMIS-015	connection	connector, angle 90°, Submin. 712-series
G-NSMIS-002	connection	2 m cable, straight connector Submin. 702-series
G-NSMIS-003	connection	2 m cable, angle 90° connector Submin. 702-series

Other cable length on request

NORTH AMERICA	EUROPE	ASIA
Measurement Specialties, Inc. 1000 Lucas Way Hampton, VA 23666 United States Phone: +1-800-745-8008 Fax: +1-757-766-4297 Email: sales@meas-spec.com Web: www.meas-spec.com	MEAS Deutschland GmbH Hauert 13 D-44227 Dortmund Germany Phone: +49-(0)231-9740-0 Fax: +49-(0)231-9740-20 Email: info.de@meas-spec.com Web: www.meas-spec.com	Measurement Specialties China Ltd. No. 26, Langshan Road High-tech Park (North) Nanshan District, Shenzhen 518057 China Phone: +86-755-33305088 Fax: +86-755-33305099 Email: info.cn@meas-spec.com Web: www.meas-spec.com

The information in this sheet has been carefully reviewed and is believed to be accurate; however, no responsibility is assumed for inaccuracies. Furthermore, this information does not convey to the purchaser of such devices any license under the patent rights to the manufacturer. Measurement Specialties, Inc. reserves the right to make changes without further notice to any product herein. Measurement Specialties, Inc. makes no warranty, representation or guarantee regarding the suitability of its product for any particular purpose, nor does Measurement Specialties, Inc. assume any liability arising out of the application or use of any product or circuit and specifically disclaims any and all liability, including without limitation consequential or incidental damages. Typical parameters can and do vary in different applications. All operating parameters must be validated for each customer application by customer's technical experts. Measurement Specialties, Inc. does not convey any license under its patent rights nor the rights of others.