

DPG-Series Inclinometer

Dual axis inclinometer
Measurement ranges
 $\pm 5^\circ$, $\pm 10^\circ$, $\pm 15^\circ$
and $\pm 30^\circ$
RS 232 and voltage output



dimensions [mm]

The **DPG-Series** dual axis conductive inclinometer in aluminum housing offers the user modern microprocessor technology with an integrated active linearization and temperature compensation. This inclinometer is full calibrated, easy to horizontal mount and absolute plug and play compatible.

FEATURES

- Robust IP67/68 housing
- High accuracy
- High resolution
- Temperature compensated
- High output data transfer
- Cable integrated
- Programmable digital filtering to minimized influences from shock and vibration

APPLICATIONS

- Mobile and stationary cranes
- Lift platforms
- Building control
- Weighing systems
- Truck chassis levelling
- Vehicle applications
- Road construction machines

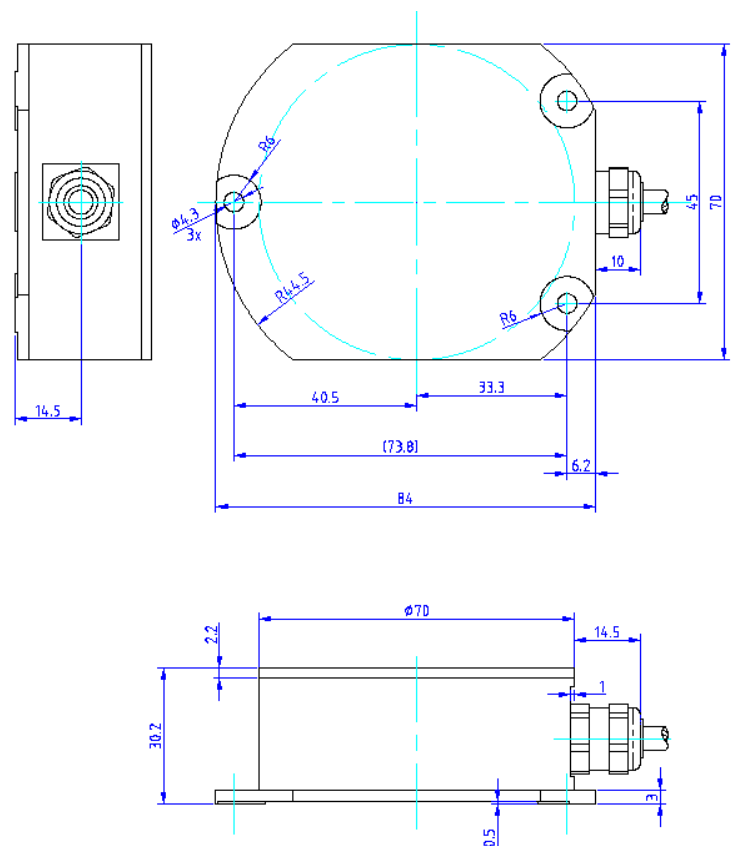

DPG-Series Inclinometer

performance specifications

PARAMETERS

	Conditions	Min	Type	Max	Unit
Measurement range		-5/-10/ -15/ -30		+5/ +10/ +15/ +30	°
Resolution		0.001			°
Accuracy 1 (absolute)	Ta = 0°...50°C		0.06/ 0.09/ 0.2/ 0.5		°
Accuracy 2 (absolute)	Ta = -40°C...+85°C		0.12/ 0.15/ 0.25/ 0.8		°
Offset temperature drift error	Ta = -25°C...+75°C		0.05		°
	Ta = -40°C...+85°C		0.1		°
Noise RMS			0.003		°
Output rate, programmable	RS 232	0.5	10	25	Hz
Baud rate, programmable	RS 232		9.6		kB
Output voltage signal	analogue	0.3		4.7	V
Current consumption			20		mA
Power supply		7		30	VDC
Operation temperature range		-40		+85	°C
Storage temperature range		-40		+85	°C
Weight			280		g
Cable, pigtail			1000		mm
Dimensions	W x D x H		84 x 70 x 31		mm

Cable configuration

No	Name	Description	Type	Cable color
1	Vcc	Positive power supply	Supply, Input	white
2	RxD	RS 232 input	Input 1	grey
3	GND	Ground	Supply, Input	yellow
4	Out X	Voltage out X	Output 2	brown
5	Out Y	Voltage out Y	Output 2	green
6	TxD	RS 232 output	Output 1	pink

For more details please use the product specification / application note / instruction manual.

The information in this sheet has been carefully reviewed and is believed to be accurate; however, no responsibility is assumed for inaccuracies. Furthermore, this information does not convey to the purchaser of such devices any license under the patent rights to the manufacturer. Measurement Specialties, Inc. reserves the right to make changes without further notice to any product herein. Measurement Specialties, Inc. makes no warranty, representation or guarantee regarding the suitability of its product for any particular purpose, nor does Measurement Specialties, Inc. assume any liability arising out of the application or use of any product or circuit and specifically disclaims any and all liability, including without limitation consequential or incidental damages. Typical parameters can and do vary in different applications. All operating parameters must be validated for each customer application by customer's technical experts. Measurement Specialties, Inc. does not convey any license under its patent rights nor the rights of others.

ordering info

PART NUMBERING	UNIT	SHORT DESCRIPTION
G-NSDPG2-003	NS- 5/DPG2-RUD	Range +/- 5°, Vcc +7... 30VDC, output RS232, voltage +0.3...+4.7V
G-NSDPG2-001	NS-10/DPG2-RUG	Range +/-10°, Vcc +7... 30VDC, output RS232, voltage +0.3...+4.7V
G-NSDPG2-002	NS-15/DPG2-RUG	Range +/-15°, Vcc +7... 30VDC, output RS232, voltage +0.3...+4.7V
G-NSDPG2-005	NS-30/DPG2-RUN	Range +/-30°, Vcc +7... 30VDC, output RS232, voltage +0.3...+4.7V