

XFTC300 Miniature Load Cell



- 0-2N to 0-2kN [0.4 lbf to 400 lbf]
- Tension and/or Compression
- High Stiffness
- For Static and Dynamic Applications
- Threaded Male Mechanical Fitting
- High Level Output with Integrated Amplifier
- High Overload Capacity



DESCRIPTION

The **XFTC300** series has been specifically developed to measure tension and/or compression in static and dynamic applications. The miniature size and light-weight facilitate testing where these conditions are necessary.

The sensing element is fitted with a fully temperature compensated Wheatstone bridge equipped with high stability micro-machined silicon strain gages. The use of silicon strain gages optimizes the load cell's performance at low ranges and frequencies. For sensors with a range of between 2 and 2kN, a high-level output model is available. With two male threads, the **XFTC300** is easily installed in industrial or OEM applications. A strain relief spring strengthens the cable output.

With many years of experience as a designer and manufacturer of sensors, Measurement Specialties, Inc. often works with customers to design or customize sensors for specific uses and testing environments. To meet your needs we also offer complete turnkey systems. The matched components (sensor, power, amplifier and digital display) are formatted, calibrated and ready for immediate use.

FEATURES

- Small design easy to mount
- Tension and/or Compression
- Heavy duty
- Wide temperature range in option
- Easy to customize signal and design

APPLICATIONS

- Dynamic strain cylinder regulation
- Miniature press-fit device
- Fatigue test benches
- Robotics regulation
- Small size actuators

STANDARD RANGES

F.S. Ranges in N	2 - 5 - 10 - 20 - 50	100	200	500 – 1k	2k
F.S. Ranges in lbf	0.4 - 1 - 2 - 4 - 10	20	40	100 – 200	400
Stiffness in N/m	3.8x10 ⁵ to 4.7x10 ⁷	7.9x10 ⁷	2.2x10 ⁸	3.4x10 ⁸ to 9.6x10 ⁸	2.7x10 ⁹
Stiffness in lbf/ft	2.6x10 ⁴ to 3.2x10 ⁵	5.4x10 ⁵	1.5x10 ⁷	2.3x10 ⁷ to 6.6x10 ⁷	1.9x10 ⁸
Material	Aluminum			Stainless Steel	

XFTC300 Miniature Load Cell

PERFORMANCE SPECIFICATIONS

All values are typical at temperature 20±1° C

PARAMETERS	
Operating Temperature Range (OTR)	-40 to 120°C [-40 to 248°F]
Compensated Temperature Range (CTR)	0 to 60° C [32 to 140°F]
Zero Shift in CTR	<2% F.S. / 50° C [100°F]
Sensitivity Shift in CTR	<2% of reading / 50° C [100°F]
Range (F.S.)	0-2N to 0-2kN [0-0.4 lbf to 0-400 lbf]
Over-Range	
Without Damage	2 to 4 x F.S.
Without Destruction	3 to 6 x F.S.
Accuracy	
Linearity	≤±0.5% F.S.
Hysteresis	≤±0.5% F.S.

Electrical Characteristics

Model	XFTC300	XFTC300-A1	XFTC300-A2
Supply Voltage	10Vdc	10 – 30Vdc	±15Vdc (±12 to ±18Vdc)
F.S. Output ⁵	±100mV	±2V ±5% F.S.	±5V ±5% F.S.
Zero Offset ⁵	<±10mV	2.5V ±5% F.S.	0V ±5% F.S.
Input Impedance/Consumption	1000 to 3000Ω	<30mA	<30mA
Output Impedance	500 to 1000Ω	<1 kΩ ⁶	<1 kΩ ⁶
Insulation under 50Vdc	≥100MΩ	≥100MΩ	≥100MΩ

Notes

1. Shielded cable with 4 wires (AWG36/28), standard length 2 m [6.5 ft] with strain relief spring
2. Material: Body in stainless steel or aluminum alloy depending on F.S., ; Two male threads M5 or [10-32 UNF], M10 or [3/8-24 UNF] depending on F.S. (metric thread is standard)
3. Protection Index: IP50 (other levels available on request)
4. A1 and A2 options are only available for ranges 500N, 1kN and 2kN
5. Standard output signal, custom outputs available on request
6. Output impedance standard, available <100Ω on request.
7. CE conformance according to EN 61010-1, EN 50081-1, EN 50082-1

XFTC300 Miniature Load Cell

DIMENSIONS & WIRING SCHEMATIC (IN METRIC AND IMPERIAL)

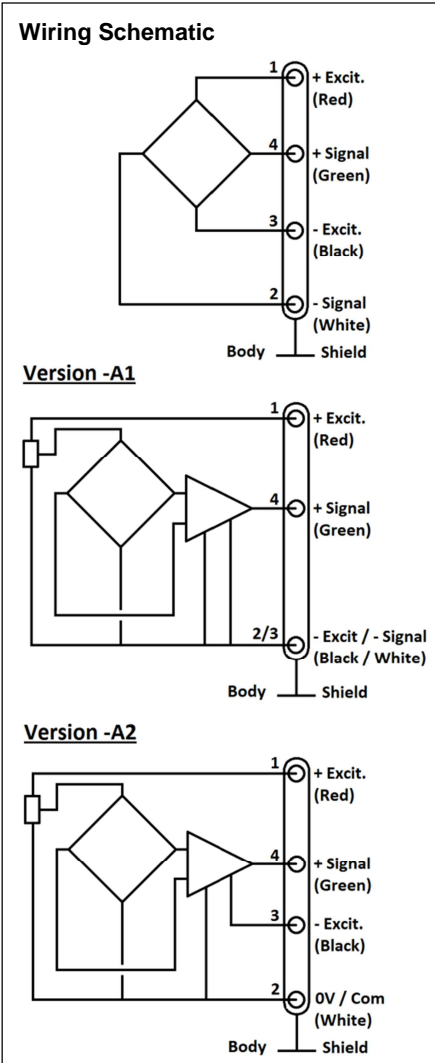
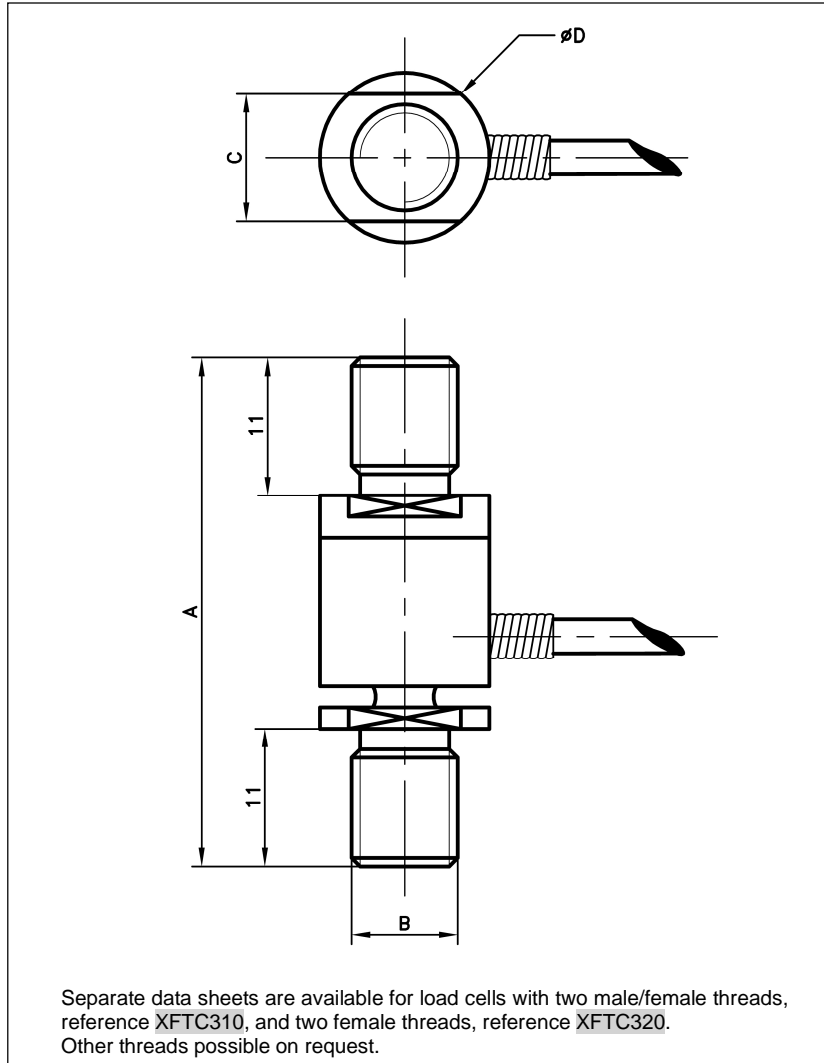

Dimensions in mm [inch]

Full Scale Range in N [in lbf]	2 - 5 - 10 - 20 - 50 [0.4 - 1 - 2 - 4 - 10]	100 - 200 [20 - 40]	500 - 1000 [100 - 200]	2000 [400]
A	36 [1.42]	36 [1.42]	46 [1.81]	46 [1.81]
B (Thread)	M5	M5	M10	M10
C	8 [0.31]	8 [0.31]	12 [0.47]	16 [0.63]
Ø D	10 [0.39]	10 [0.39]	16 [0.63]	20 [0.79]
Material	Aluminum Alloy	Stainless Steel		
Stiffness in N/m	3.8x10 ⁵ to 4.7x10 ⁷	7.9x10 ⁷ to 2.2x10 ⁸	3.4x10 ⁸ to 9.6x10 ⁸	2.7x10 ⁹
Stiffness in lbf/ft	2.4x10 ⁴ to 3.2x10 ⁶	5.4x10 ⁶ to 1.5x10 ⁷	2.3x10 ⁷ to 6.6x10 ⁷	1.9x10 ⁸
Over-range	x4	x3	x3	x2

XFTC300 Miniature Load Cell

OPTIONS

A1	: Tension output with unipolar power supply (only available for ranges 500N, 1kN and 2kN)
A2	: Tension output with bipolar power supply (only available for ranges 500N, 1kN and 2kN)
ET1	: CTR -20 to 100° C [-4 to 212°F]
ET2	: CTR -40 to 120° C [-40 to 248°F]
ET3	: CTR -40 to 150° C [-40 to 302°F] OTR=CTR (option not compatible with A1 and A2 versions)
HA	: Accuracy (CNL&H) $\pm 0.5\%$ F.S. (for models $\geq 100\text{N}$; 20lbf)
TS	: Tolerance on F.S. output $\leq \pm 2\%$ F.S. (compatible with A1 and A2 versions only)
L00M	: special cable length, replace "00" with total length in meters

ORDERING INFO

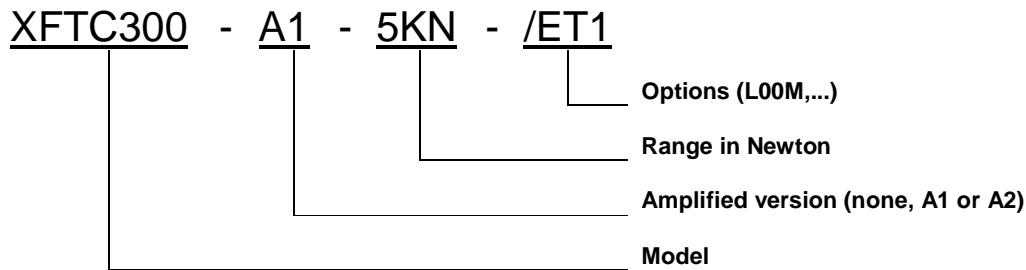

NORTH AMERICA

Measurement Specialties, Inc.
Vibration Design Center
32 Journey - Suite 150
Aliso Viejo, CA 92656
United States USA
Tel: 1-949-716-0877
Fax: 1-949-916-5677
t&m@meas-spec.com

EUROPE

Measurement Specialties
(Europe), Ltd.
26 Rue des Dames
78340 Les Clayes-Sous-Bois,
France
Tel: +33 (0) 130 79 33 00
Fax: +33 (0) 134 81 03 59
cs.lcsb@meas-spec.com

ASIA

Measurement Specialties
(China), Ltd.
No. 26 Langshan Road
Shenzhen High-Tech Park (North)
Nanshan District, Shenzhen
518057
China
Tel: +86 755 3330 5088
Fax: +86 755 3330 5099
pfg.cs.asia@meas-spec.com

The information in this sheet has been carefully reviewed and is believed to be accurate; however, no responsibility is assumed for inaccuracies. Furthermore, this information does not convey to the purchaser of such devices any license under the patent rights to the manufacturer. Measurement Specialties, Inc. reserves the right to make changes without further notice to any product herein. Measurement Specialties, Inc. makes no warranty, representation or guarantee regarding the suitability of its product for any particular purpose, nor does Measurement Specialties, Inc. assume any liability arising out of the application or use of any product or circuit and specifically disclaims any and all liability, including without limitation consequential or incidental damages. Typical parameters can and do vary in different applications. All operating parameters must be validated for each customer application by customer's technical experts. Measurement Specialties, Inc. does not convey any license under its patent rights nor the rights of others.