

FC23 Compression Load Cell



- 50 – 2000 lbf Ranges
- High Level or mV
- Interchangeable
- Compact Load Button Design
- Industry Standard Packaging

DESCRIPTION

The FC23 is a high compression force sensor that creates new markets previously unrealizable due to cost and performance constraints. The FC23 offers normalized zero and span for interchangeability and is thermally compensated for changes in zero and span with respect to temperature.

The FC23 incorporates MEAS' proprietary Microfused™ technology which employs micromachined silicon piezoresistive strain gages fused with high temperature glass to a high performance stainless steel substrate. Microfused™ technology eliminates age-sensitive organic epoxies used in traditional load cell designs providing excellent long term span and zero stability. The FC23 measures direct force and is therefore not subject to lead-die fatigue failure common with competitive designs which use a pressure capsule embedded within a silicone gel-filled cavity. Operating at very low strains, Microfused™ technology provides an essentially unlimited cycle life expectancy, superior resolution, and high over-range capabilities.

The FC23 brings your OEM product to life whether you need thousands or millions of load cells annually. Although the standard model is ideal for a wide range of applications, our dedicated design team at our Load Cell Engineering Center is ready to provide you with custom designs for your OEM applications.

Please refer to models FS20 and FC22 for lower force applications.

FEATURES

- Interchangeable
- Low Noise
- Robust: High Over-Range Capability
- High Reliability
- Low Deflection
- Low Off Center Errors
- Fast Response Time
- Long Cycle Life Expectancy

APPLICATIONS

- Batch Weighing
- Robotics End-Effectors
- Variable Force Control
- Load and Compression Sensing
- Assembly Line Force Measurement
- Pumps
- Hoist and Winch Loads
- Weighing

STANDARD RANGES

Range	lbf
0 to 50	•
0 to 100	•
0 to 250	•
0 to 500	•
0 to 1000	•
0 to 2000	•

FC23 Compression Load Cell

PERFORMANCE SPECIFICATIONS

Supply Voltage: 5.0V, Ambient Temperature: 25°C (unless otherwise specified)

PARAMETERS	MIN	TYP	MAX	UNITS	NOTES
Span (Unamplified)	95	100	105	mV	1
Span (Amplified)	3.8	4.0	4.2	V	1
Zero Force Output (Unamplified)	-20	0	20	mV	1
Zero Force Output (Amplified)	0.3	0.5	0.7	V	1
Accuracy (non linearity, hysteresis, and repeatability)	-1		1	%Span	2
Input Resistance (Unamplified)		3		kΩ	
Output Resistance (Unamplified)		2.2		kΩ	
Temperature Error – Span	-2.5	±1	2.5	%Span	3
Temperature Error – Zero	-2.5	±1	2.5	%Span	3
Supply Voltage (Unamplified)	2	5	10	V	1
Supply Voltage (Amplified)	3.3	5	5.25	V	1
Response Time (10% to 90%)		1.0		ms	
Long Term Stability (1 year)		±1		%Span	
Maximum Overload			2.5X	Rated	
Compensated Temperature	0		50	°C	
Operating Temperature	-40		+85	°C	
Storage Temperature	-40		+85	°C	
Isolation Resistance (250Vdc)	50			MΩ	
Deflection at Rated Load			0.05	mm	
Humidity	0		90	%RH	
Weight		47.23		grams	

For custom configurations, consult factory.

Notes

1. Ratiometric to supply.
2. Best fit straight line.
3. Maximum temperature error over compensated range with respect to 25°C.

CE Compliance

IEC61000-4-2: [4kV/ 4 kV (Air/Contact)]

IEC61000-4-3: (3 V/m)

FC23 Compression Load Cell

DIMENSIONS

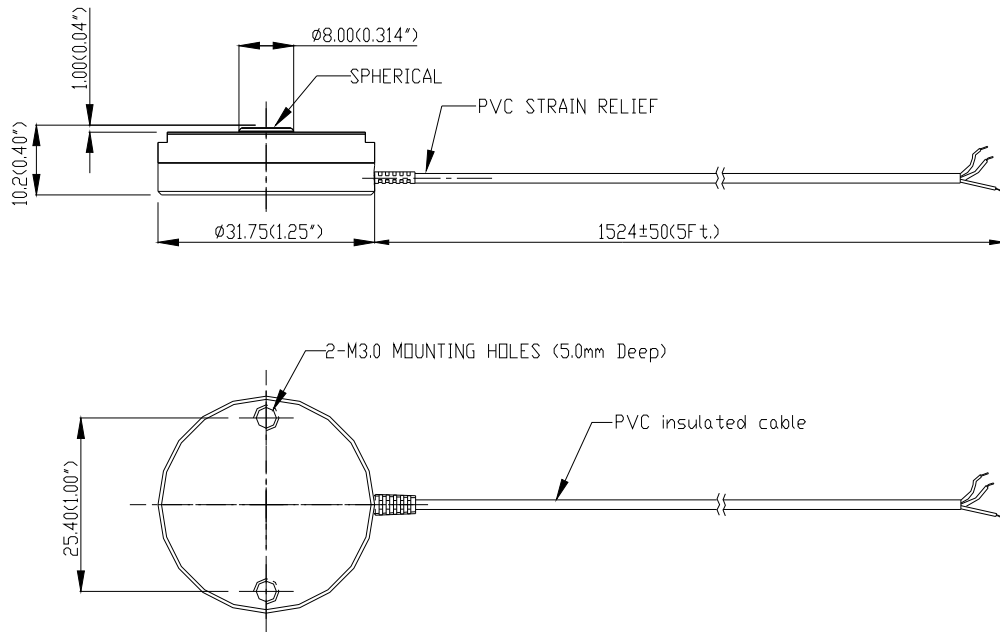

CONNECTIONS

High Level Amplified Output

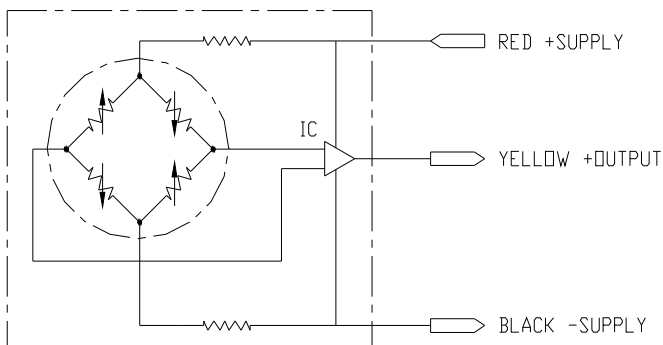

Millivolt Bridge Version

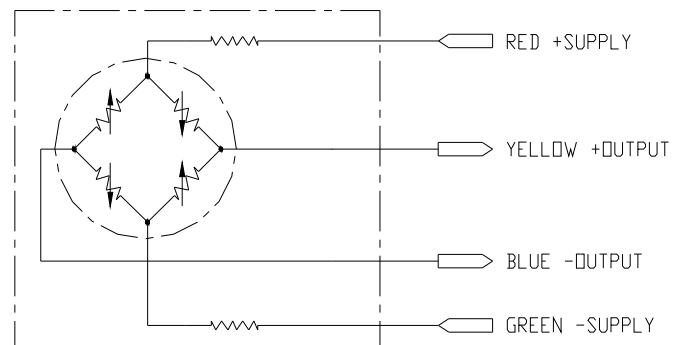

FC23 Compression Load Cell

ORDERING INFORMATION

FC23 1 1 - 0000 - 0250 - L

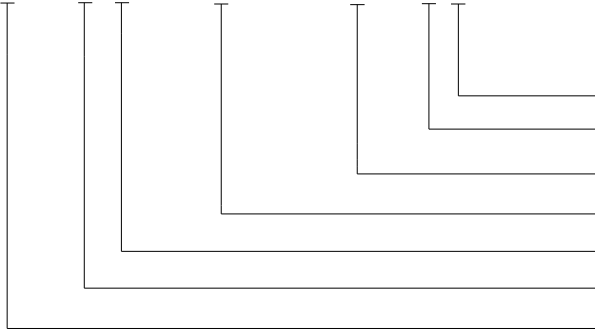

Units (L = lbf, N = Newtons)
Multiplier (- = None, K = X1000)
Force Range
Specials (Reserved for Custom Designs)
Connection (1 = 2ft Cable)
Output (1 = 20 mV, 3 = 0.5 - 4.5V)
Model

NORTH AMERICA

Measurement Specialties
45738 Northport Loop West
Fremont, CA 94538
Tel: 1-800-767-1888
Fax: 1-510-498-1578
Sales: pfg.cs.amer@meas-spec.com

EUROPE

Measurement Specialties
(Europe), Ltd.
26 Rue des Dames
78340 Les Clayes-sous-Bois, France
Tel: +33 (0) 130 79 33 00
Fax: +33 (0) 134 81 03 59
Sales: pfg.cs.emea@meas-spec.com

ASIA

Measurement Specialties
(China), Ltd.
No. 26 Langshan Road
Shenzhen High-Tech Park (North)
Nanshan District, Shenzhen 518107
China
Tel: +86 755 3330 5088
Fax: +86 755 3330 5099
Sales: pfg.cs.asia@meas-spec.com

The information in this sheet has been carefully reviewed and is believed to be accurate; however, no responsibility is assumed for inaccuracies. Furthermore, this information does not convey to the purchaser of such devices any license under the patent rights to the manufacturer. Measurement Specialties, Inc. reserves the right to make changes without further notice to any product herein. Measurement Specialties, Inc. makes no warranty, representation or guarantee regarding the suitability of its product for any particular purpose, nor does Measurement Specialties, Inc. assume any liability arising out of the application or use of any product or circuit and specifically disclaims any and all liability, including without limitation consequential or incidental damages. Typical parameters can and do vary in different applications. All operating parameters must be validated for each customer application by customer's technical experts. Measurement Specialties, Inc. does not convey any license under its patent rights nor the rights of others.